

NOTES

- 1. SYSTEM WEIGHT: 13 KG PCM, 3.4 KG PRINthead (DRY)
- 2. POWER REQUIREMENTS: 120/240 VAC 50/60 HZ
- 3. COOLING WATER REQUIREMENTS: 2 LPM
- 4. GAS SUPPLY REQUIREMENTS: CLEAN DRY AIR OR LABORATORY GRADE NITROGEN, 0.7 BAR 500 SCCM

REVISIONS				
ZONE	REV.	DESCRIPTION	DATE	EC
	C	UPDATE ELECTRIC CURRENT, FUSE	3/5/2026	02138

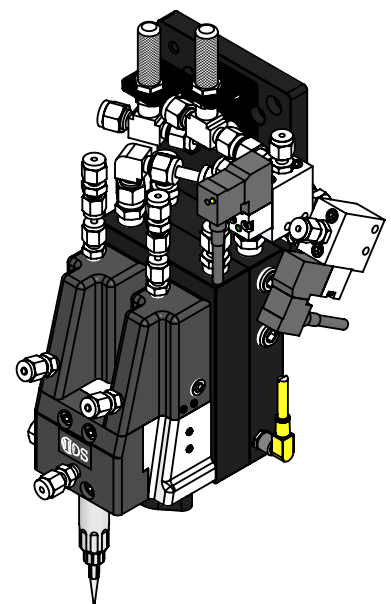

PROCESS CONTROL MODULE (PCM)

PRINT HEAD

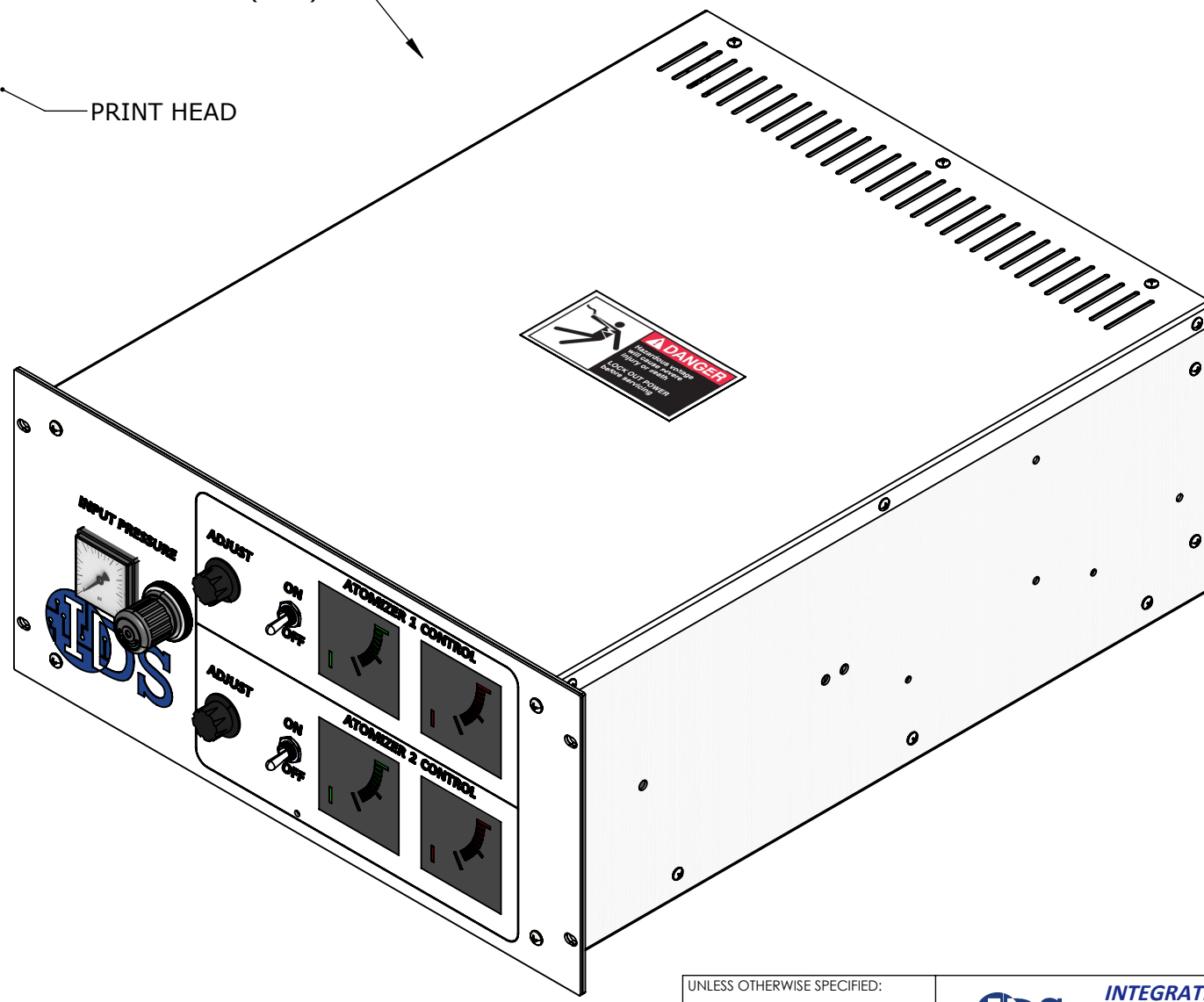

MAIN GAS REGULATOR ADJUSTMENT AND GAUGE

ATOMIZER POWER ADJUSTMENT 16 - 48VDC

ATOMIZER POWER ON/OFF TOGGLE SWITCH

ATOMIZER VOLTMETER AND AMMETER READOUTS

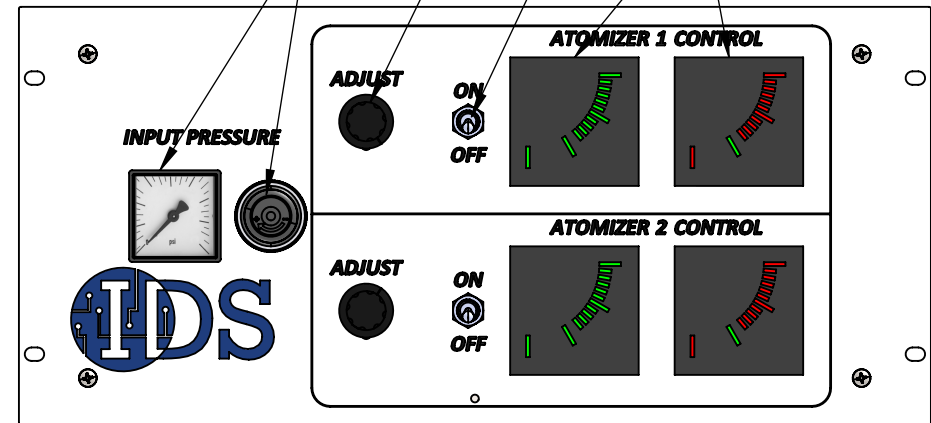

UNLESS OTHERWISE SPECIFIED:
DIMENSIONS ARE IN MILLIMETERS

TOLERANCES
NO DECIMALS ±0.5 MM
ONE PLACE DECIMAL ±0.2 MM
TWO PLACE DECIMAL ±0.1 MM
ANGULAR ±0.5°

DIMENSIONS IN PARENTHESIS FOR REFERENCE ONLY

INTERPRET GEOMETRIC TOLERANCING PER: ANSI

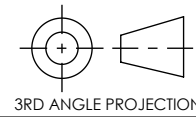

3RD ANGLE PROJECTION

PROPRIETARY AND CONFIDENTIAL
THIS DRAWING IS THE SOLE PROPERTY OF IDS (INTEGRATED DEPOSITION SOLUTIONS, INC). ANY REPRODUCTION IN PART OR AS A WHOLE WITHOUT THE WRITTEN PERMISSION OF IDS IS PROHIBITED.

IDS INTEGRATED DEPOSITION SOLUTIONS, Inc.
609 Osuna Rd, NE, Albuquerque, NM
www.idsnm.com

TITLE:
FACILITY DRAWING, GEN1 NANOJET DUAL MATERIAL

MATERIAL

FINISH

DO NOT SCALE DRAWING

DWG. NO.

SCALE: 1:4

SIZE B

SHEET 1 OF 4

REV
C

6

5

4

3

2

1

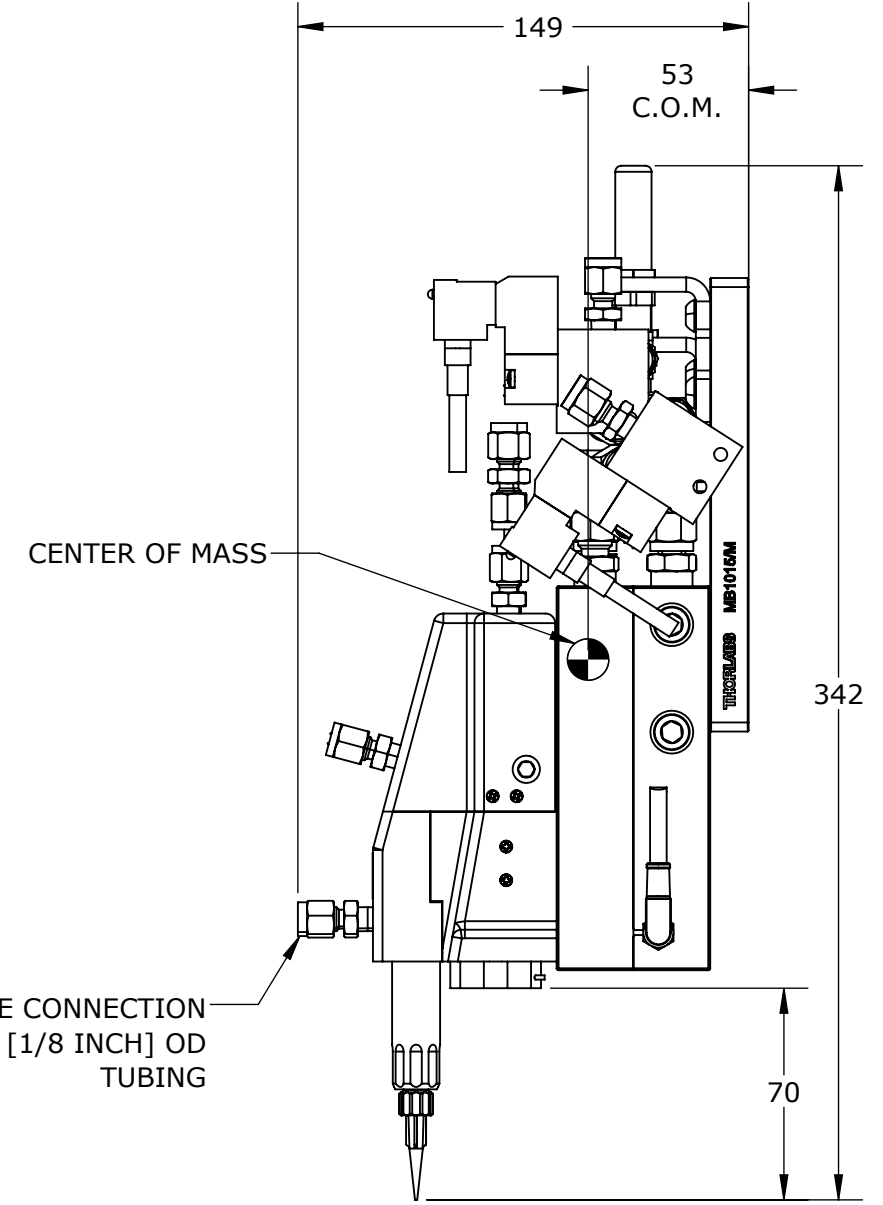
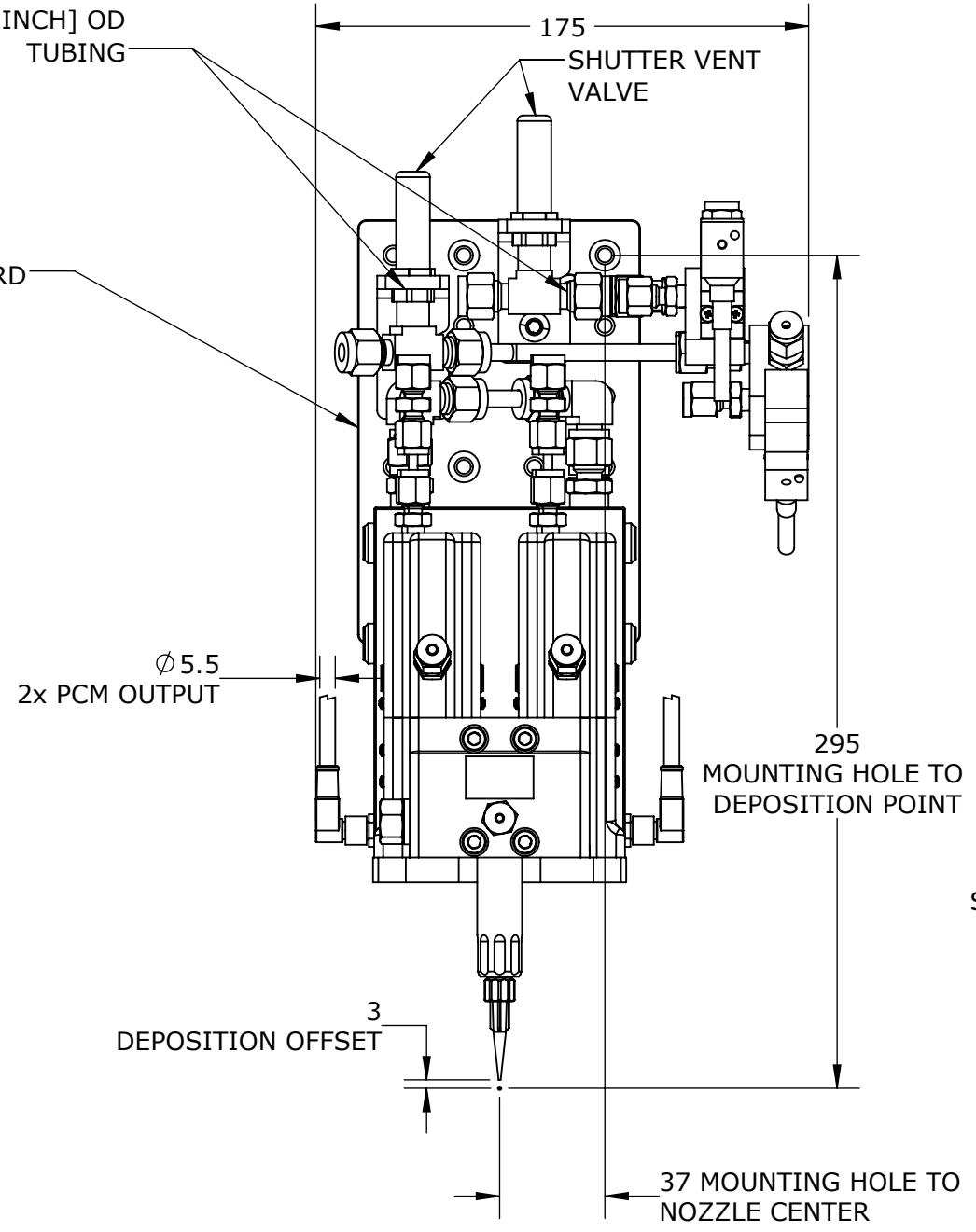
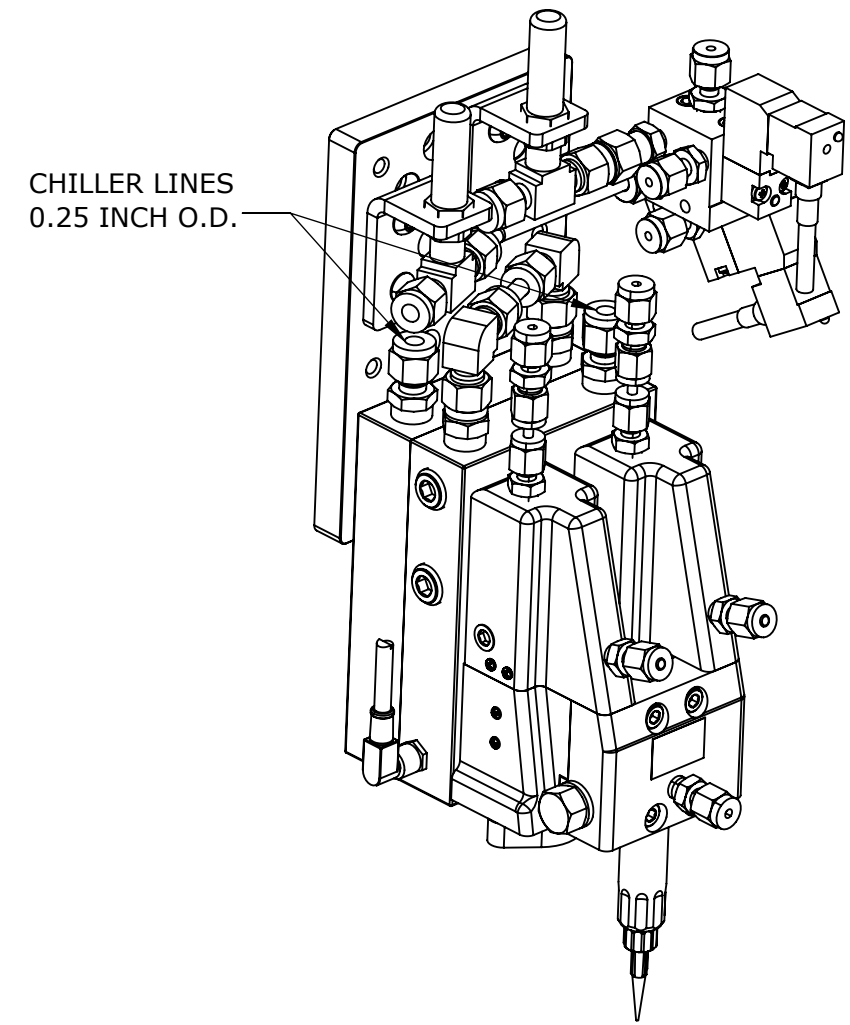
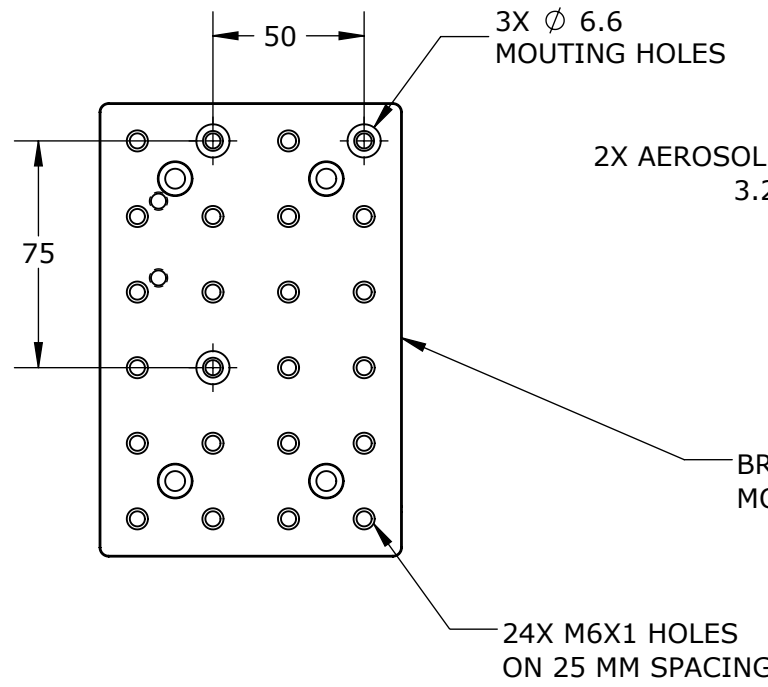

IDS INTEGRATED DEPOSITION SOLUTIONS, Inc.
609 Osuna Rd, NE, Albuquerque, NM
www.idsnm.com

TITLE:
FACILITY DRAWING, GEN1 NANOJET DUAL MATERIAL

DWG. NO. _____ REV **C**

SCALE: 1:2.5 SIZE B SHEET 2 OF 4

6

5

4

3

2

1

D

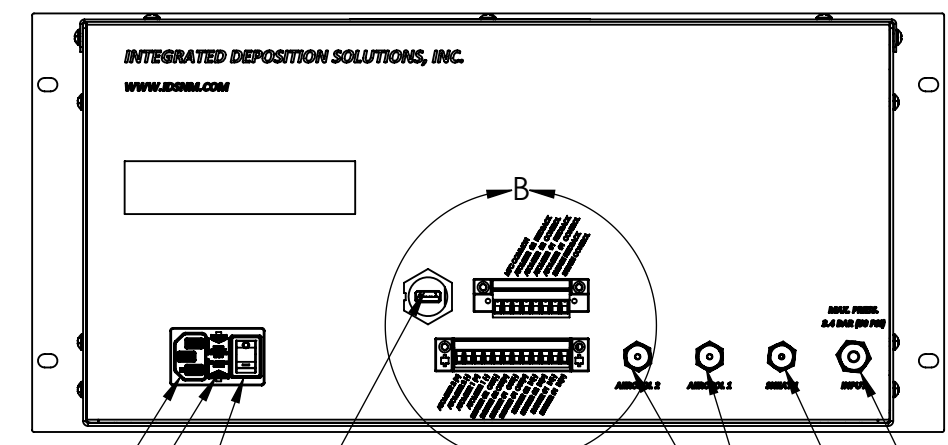
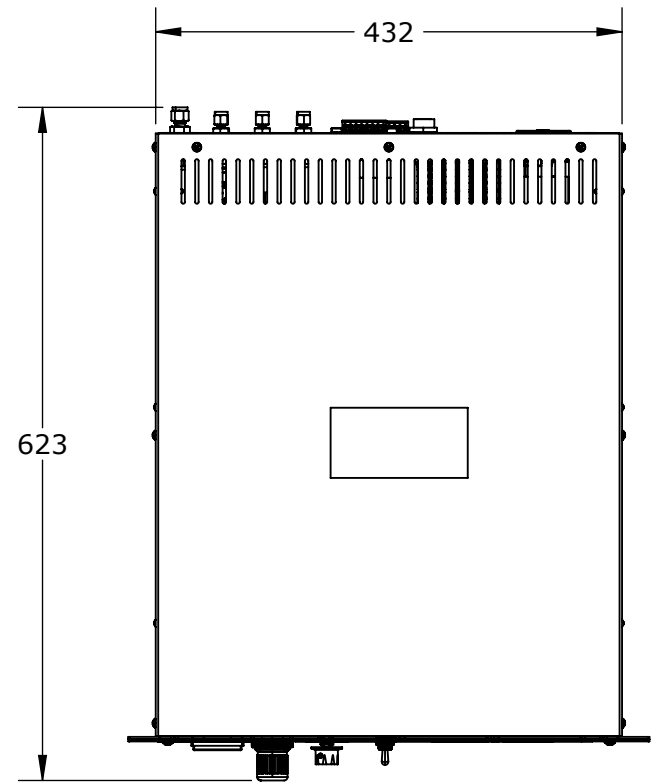

- POWER CORD SOCKET
120/240 VAC 50/60 HZ IEC C14
- FUSE, 3A 250VAC 5X20 MM
- POWER SWITCH
- USB CONNECTION TO CONTROL COMPUTER
- ATOMIZER LINES TO PRINT HEAD
3.2 [1/8"]
- CLEAN-DRY-AIR (CDA)
6.4 [1/4"]
MAX. 3.4 BAR (50 PSI)
- SHEATH LINE TO PRINT HEAD
3.2 [1/8"]

C

B

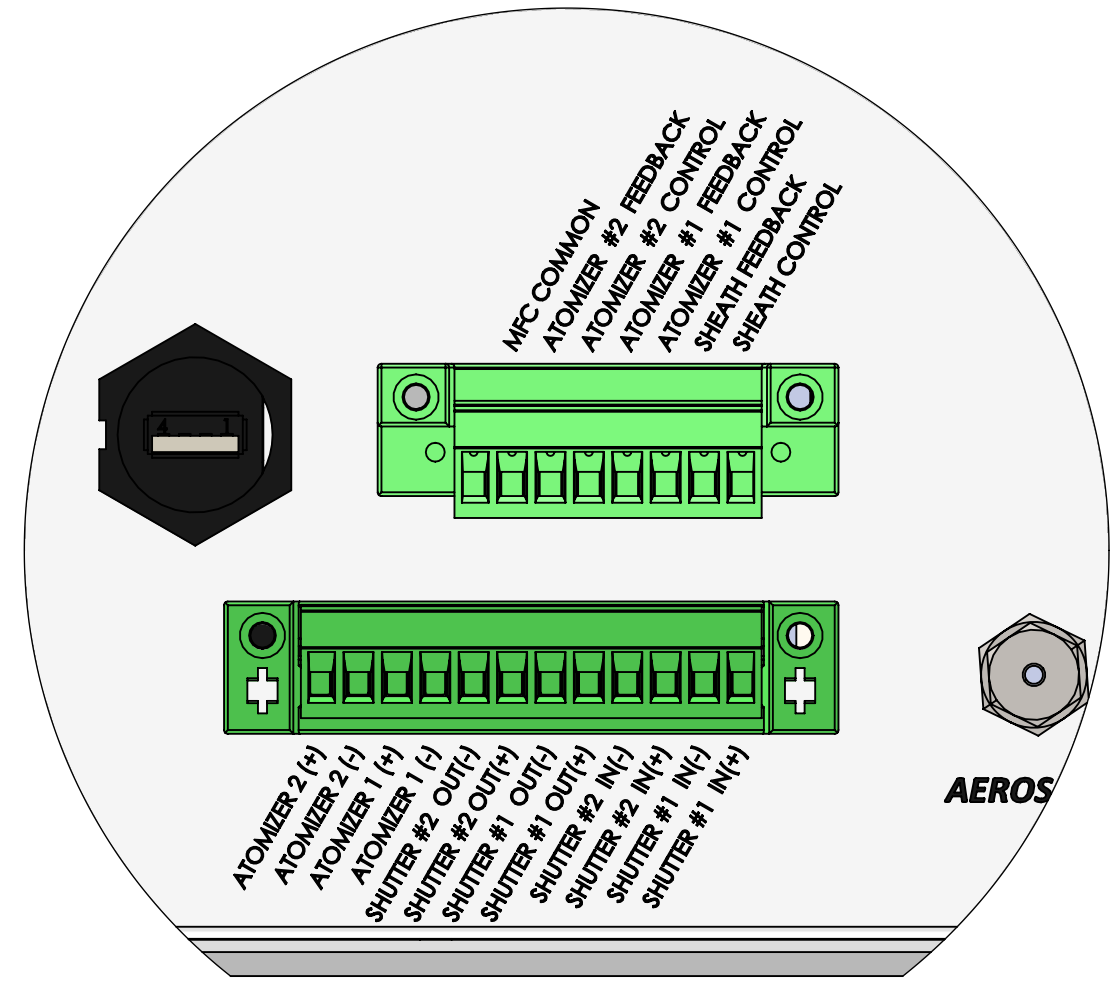
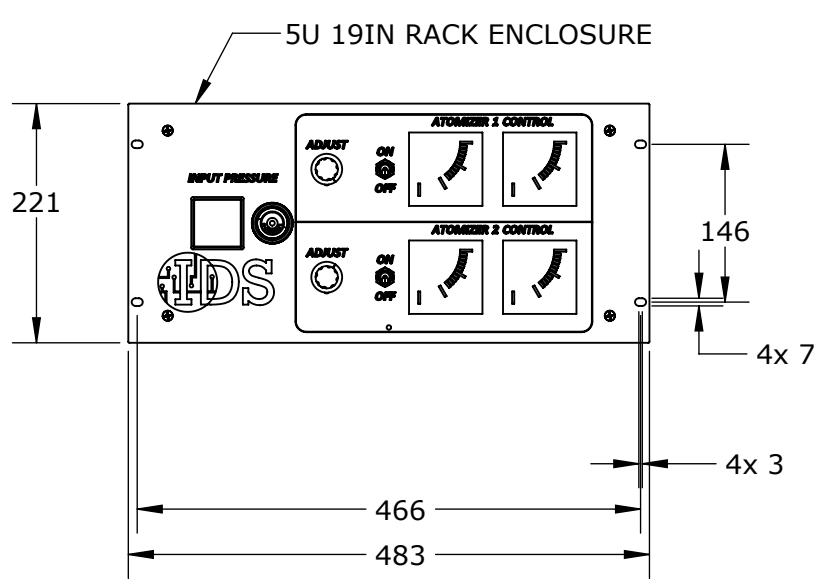

DETAIL B
SCALE 1 : 1

IDS INTEGRATED DEPOSITION SOLUTIONS, Inc.
609 Osuna Rd, NE, Albuquerque, NM
www.idsnm.com

TITLE:
**FACILITY DRAWING, GEN1
NANOJET DUAL MATERIAL**

DWG. NO. _____ REV **C**

SCALE: 1:7 SIZE B SHEET 3 OF 4

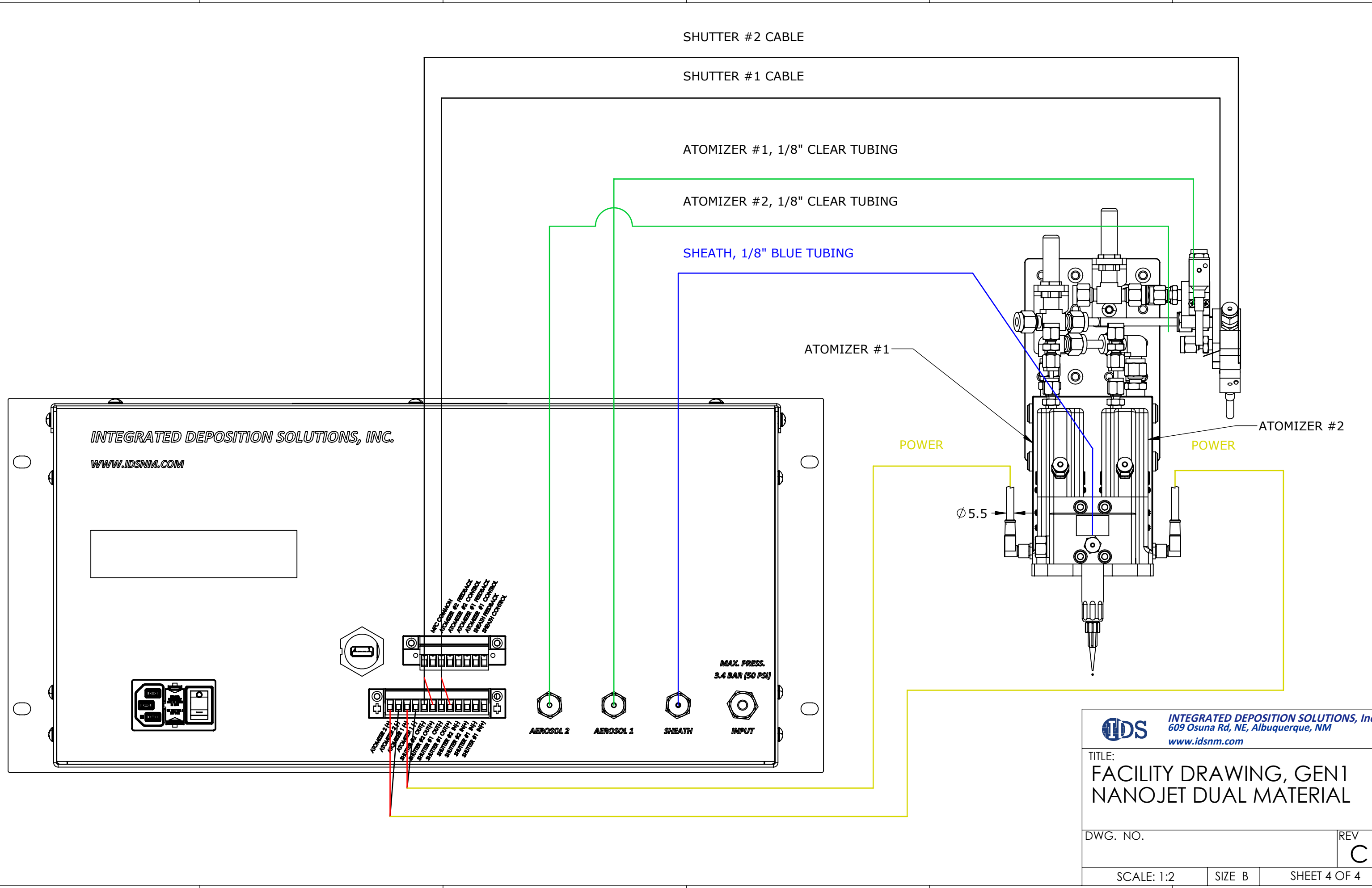

IDS INTEGRATED DEPOSITION SOLUTIONS, Inc.
609 Osuna Rd, NE, Albuquerque, NM
www.idsnm.com

TITLE:
**FACILITY DRAWING, GEN1
NANOJET DUAL MATERIAL**

DWG. NO. _____ REV **C**

SCALE: 1:2 SIZE B SHEET 4 OF 4